

339-9SUGSURSUBW/S1182/MS

Features

- Popular T-1 3/4 round package.
- High efficiency.
- Available on tape and reel.
- Built in red, green, and blue chips.
- The product itself will remain within RoHS compliant version



Descriptions

- The series is specially designed for applications requiring higher brightness
- The LED lamps are available with different colors, intensities, epoxy, colors, etc.

Applications

- Status indicators.
- Commercial use.
- Advertising Signs.
- Message board

Device Selection Guide

LED Part No.	Chip		Lens Color
	Material	Emitted Color	
339-9SUGSURSUBW/S1182/MS	AlGaInP	Brilliant Red	White diffused
	InGaN	Brilliant Green	

	InGaN	Blue	
--	-------	------	--

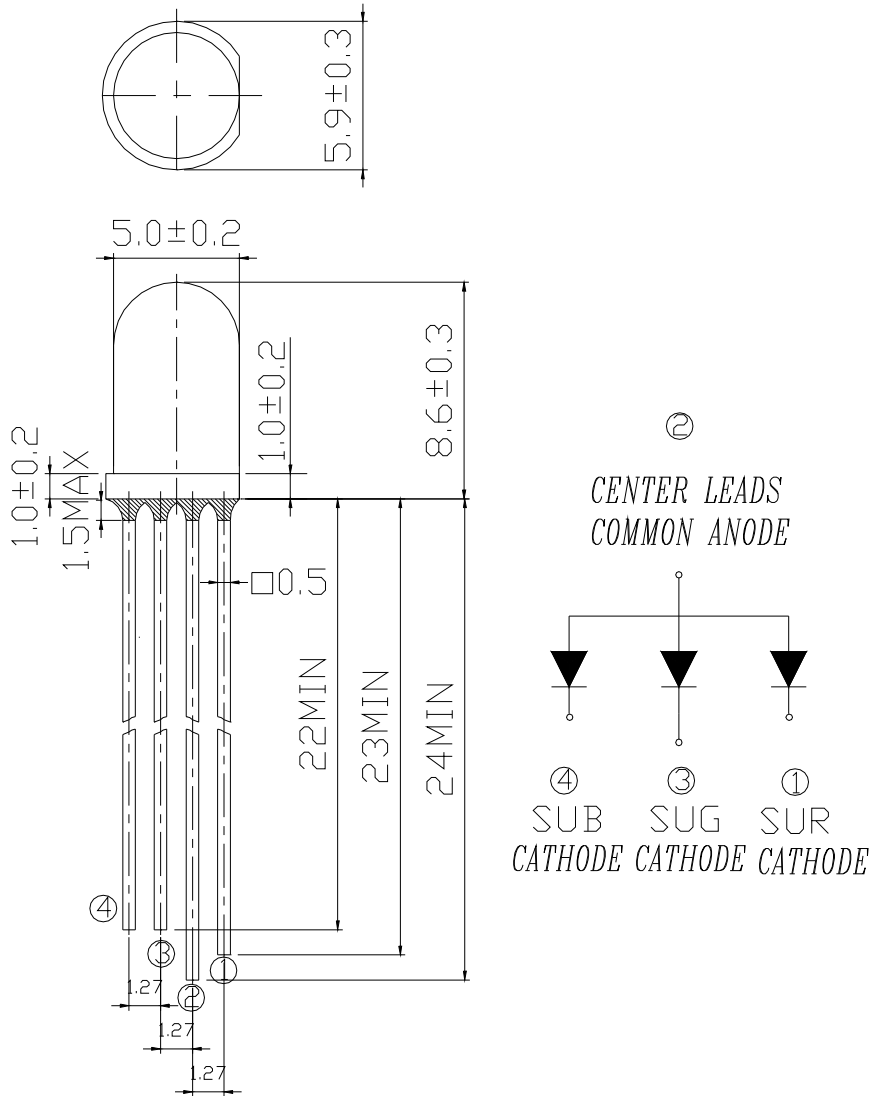

Notes:

- All dimensions are in millimeters, tolerance is 0.25mm except being specified.
- Lead spacing is measured where the lead emerges from the package.
- Protruded resin under flange is 1.5mm Max LED.

Absolute Maximum Ratings (Ta=25)

Parameter	Symbol	Blue	Green	Red	Units
Forward Current	I _F	30	30	50	mA
Pulse Forward Current (Duty1/10@ 1KHz)	I _{FP}	100	100	100	mA
Operating Temperature	T _{opr}	-40 ~ +85			
Storage Temperature	T _{stg}	-40 ~ +100			
Electrostatic Discharge	ESD	1000	1000	2000	V
Soldering Temperature	T _{sol}	260			
Power Dissipation	P _d	110	110	120	mW
Reverse Voltage	V _R	5			V

*Notes: Soldering time 5 seconds.

Electro-Optical Characteristics (Ta=25)

Parameter	Symbol	Color	Min.	Typ.	Max.	Unit	Condition
Luminous Intensity	I _v	R/G/B Three in one	1800	----	4500	mcd	R I _F =15 mA G I _F =15 mA B I _F =9 mA
Viewing Angle	2θ1/2	R/G/B Three in one	-----	65	-----	deg	R I _F =15 mA G I _F =15 mA B I _F =9 mA
Forward Voltage	V _F	SUR	-----	2.0	-----	V	R I _F =15 mA
		SUG	-----	3.0	-----		G I _F =15 mA
		SUB	-----	2.75	-----		B I _F =9 mA
		SUR	1.6	2.0	2.4		R I _F =20 mA
		SUG	2.8	3.2	3.6		G I _F =20mA
		SUB	2.8	3.2	3.6		B I _F =20mA
Reverse Current	I _R	SUR	-----	-----	10	μA	V _R =5V
		SUG			50		
		SUB			50		

*Measurement Uncertainty of Luminous Intensity: ±10%

*Measurement Uncertainty of Forward Voltage: ±0.1V

Luminous Intensity Combination
(mcd at R $I_F=15mA$ G $I_F=15mA$ B $I_F=9mA$)

Rank	Min	Max
M	1800	2250
N	2250	2850
P	2850	3600
Q	3600	4500

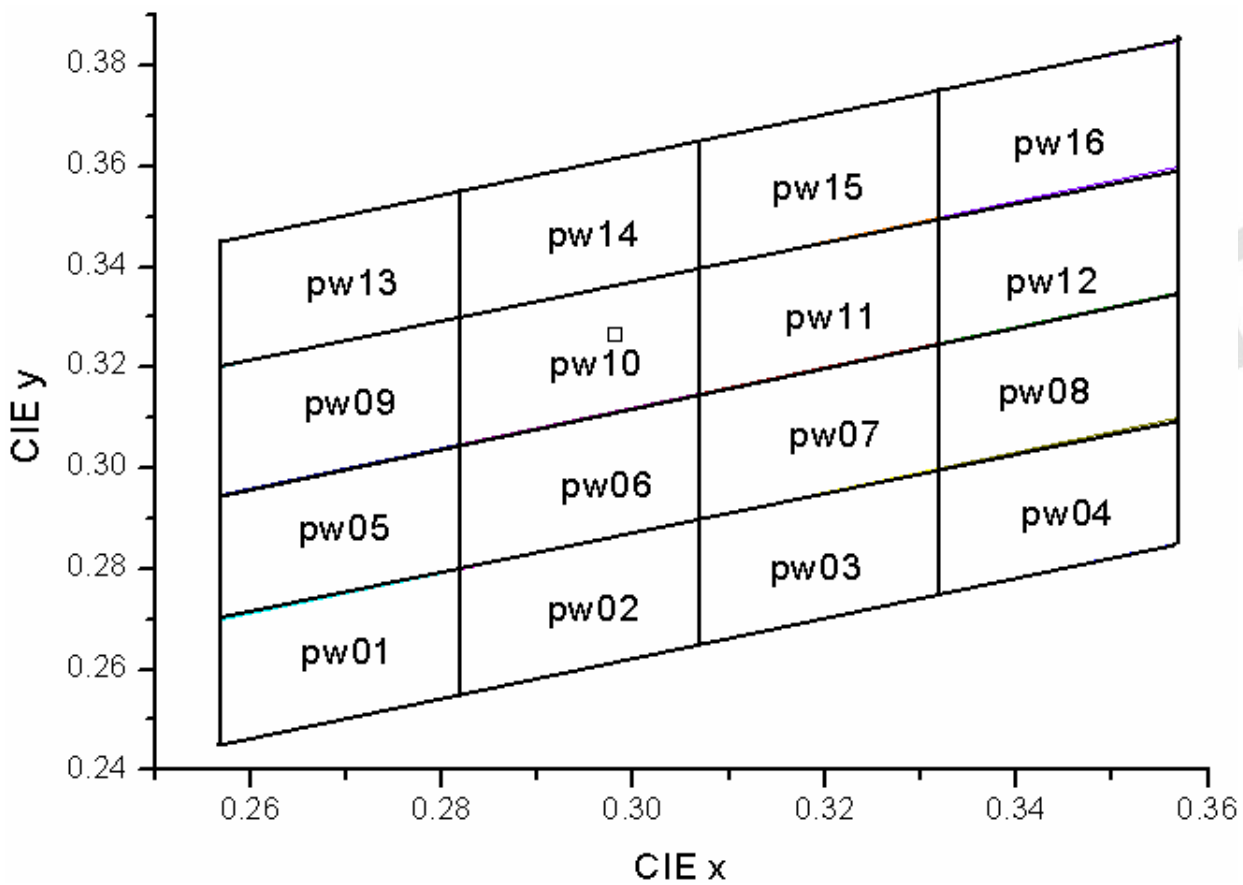

Color Ranks (Ta=25)

(R IF=15mA G IF=15mA B IF=9mA , Three devices are lit simultaneously.)

pw01		pw02		pw03		pw04	
X	Y	X	Y	X	Y	X	Y
0.257	0.245	0.282	0.255	0.307	0.265	0.332	0.275
0.257	0.27	0.282	0.28	0.307	0.29	0.332	0.3
0.282	0.28	0.307	0.29	0.332	0.3	0.357	0.31
0.282	0.255	0.307	0.265	0.332	0.275	0.357	0.285
pw05		pw06		pw07		pw08	
X	Y	X	Y	X	Y	X	Y
0.257	0.27	0.282	0.28	0.307	0.29	0.332	0.3
0.257	0.295	0.282	0.305	0.307	0.315	0.332	0.325
0.282	0.305	0.307	0.315	0.332	0.325	0.357	0.335
0.282	0.28	0.307	0.29	0.332	0.3	0.357	0.31
pw09		pw10		pw11		pw12	
X	Y	X	Y	X	Y	X	Y
0.257	0.295	0.282	0.305	0.307	0.315	0.332	0.325
0.257	0.32	0.282	0.33	0.307	0.34	0.332	0.35
0.282	0.33	0.307	0.34	0.332	0.35	0.357	0.36
0.282	0.305	0.307	0.315	0.332	0.325	0.357	0.335
pw13		pw14		pw15		pw16	
X	Y	X	Y	X	Y	X	Y
0.257	0.32	0.282	0.33	0.307	0.34	0.332	0.35
0.257	0.345	0.282	0.355	0.307	0.365	0.332	0.375
0.282	0.355	0.307	0.365	0.332	0.375	0.357	0.385
0.282	0.33	0.307	0.34	0.332	0.35	0.357	0.36

*Measurement uncertainty of the color coordinates : ± 0.01

Typical Electro-Optical Characteristics Curves

Relative Intensity vs. Wavelength

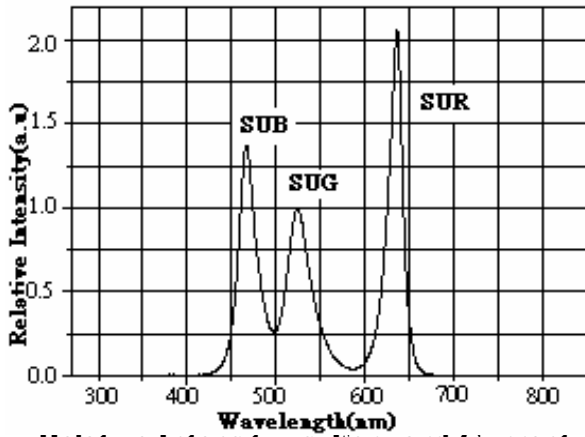

Forward Current vs. Forward Voltage

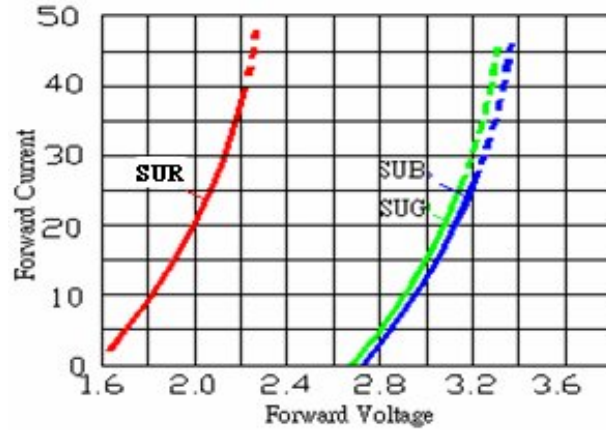

Relative Intensity vs. Forward Current

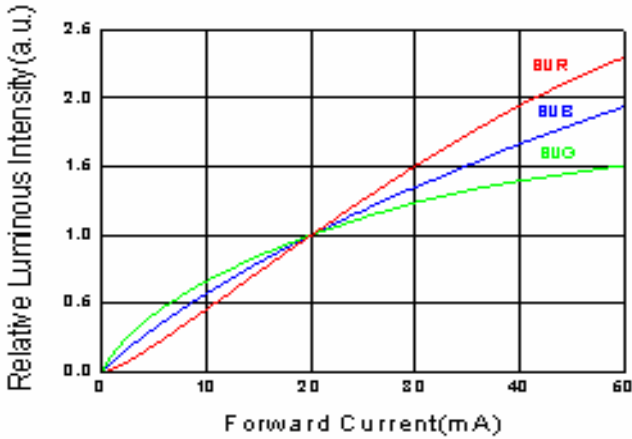

Forward Current vs. Ambient Temp.

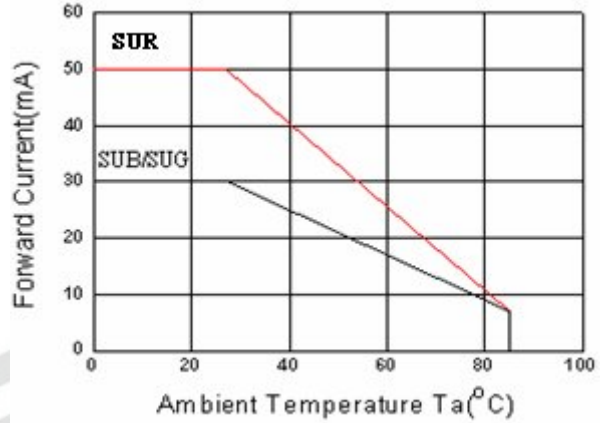

Chromaticity Coordinate vs. Forward Current

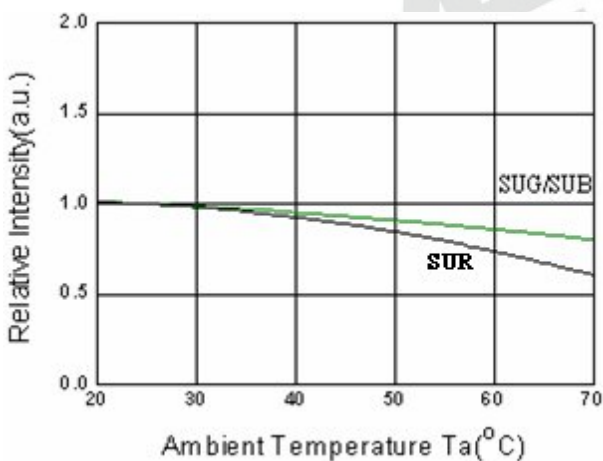

Relative Intensity vs. Angle Displacement

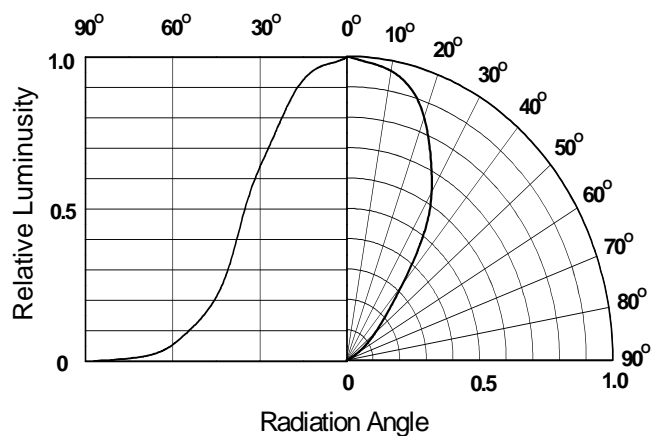

Packing Specification

Anti-electrostatic bag

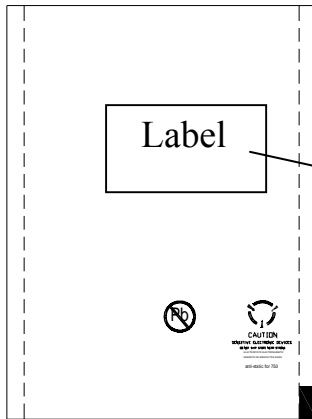

Inner Carton

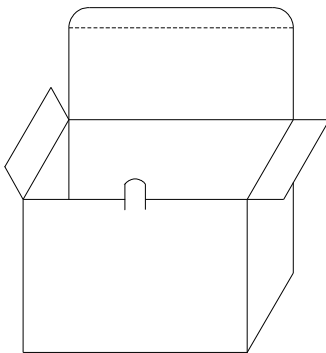

Outside Carton

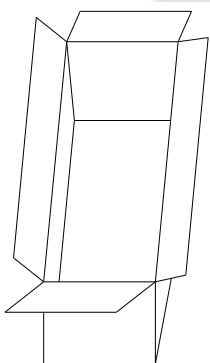

Label Form Specification

CPN: Customer's Production Number

P/N : Production Number

QTY: Packing Quantity

CAT: Rank of Luminous Intensity

HUE: Rank of Dominant Wavelength

REF: Reference

LOT No: Lot Number

MADE IN TAIWAN: Production Place

Packing Quantity

1. 500 PCS/1 Bag, 5 Bags/1 Inner Carton
2. 10 Inner Cartons/1 Outside Carton

Notes

1. Lead Forming

- During lead formation, the leads should be bent at a point at least 3mm from the base of the epoxy bulb.
- Lead forming should be done before soldering.
- Avoid stressing the LED package during leads forming. The stress to the base may damage the LED's characteristics or it may break the LEDs.
- Cut the LED leadframes at room temperature. Cutting the leadframes at high temperatures may cause failure of the LEDs.
- When mounting the LEDs onto a PCB, the PCB holes must be aligned exactly with the lead position of the LED. If the LEDs are mounted with stress at the leads, it causes deterioration of the epoxy resin and this will degrade the LEDs.

2. Storage

- The LEDs should be stored at 30°C or less and 70%RH or less after being shipped from Everlight and the storage life limits are 3 months. If the LEDs are stored for 3 months or more, they can be stored for a year in a sealed container with a nitrogen atmosphere and moisture absorbent material.
- Please avoid rapid transitions in ambient temperature, especially, in high humidity environments where condensation can occur.

3. Soldering

- Careful attention should be paid during soldering. When soldering, leave more than 3mm from solder joint to epoxy bulb, and soldering beyond the base of the tie bar is recommended.
- Recommended soldering conditions:

Hand Soldering		DIP Soldering	
Temp. at tip of iron	300 Max. (30W Max.)	Preheat temp.	100 Max. (60 sec Max.)
Soldering time	3 sec Max.	Bath temp. & time	260 Max., 5 sec Max
Distance	3mm Min.(From solder joint to epoxy bulb)	Distance	3mm Min. (From solder joint to epoxy bulb)

Recommended soldering profile

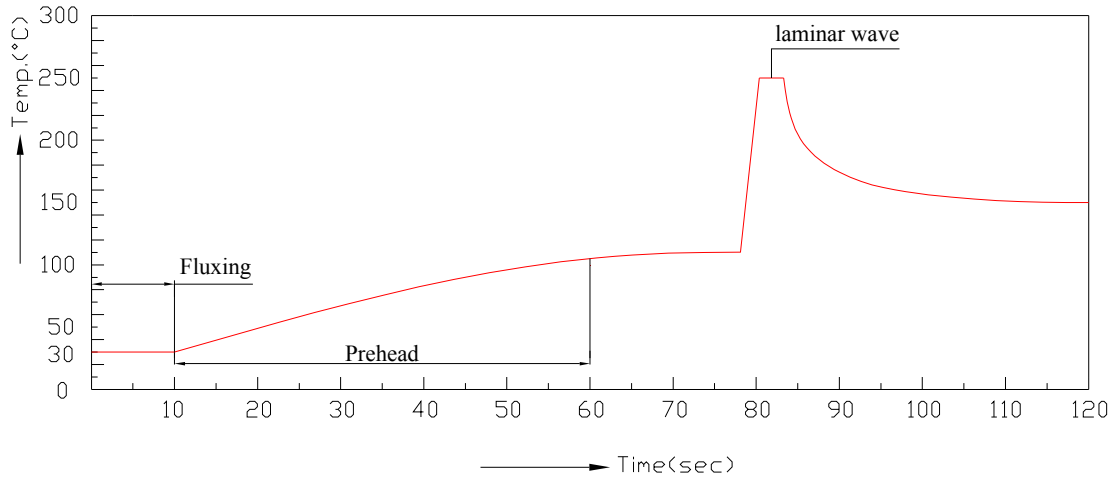

- Avoiding applying any stress to the lead frame while the LEDs are at high temperature particularly when soldering.
- Dip and hand soldering should not be done more than one time
- After soldering the LEDs, the epoxy bulb should be protected from mechanical shock or vibration until the LEDs return to room temperature.
- A rapid-rate process is not recommended for cooling the LEDs down from the peak temperature.
- Although the recommended soldering conditions are specified in the above table, dip or handsoldering at the lowest possible temperature is desirable for the LEDs.
- Wave soldering parameter must be set and maintain according to recommended temperature and dwell time in the solder wave.

4. Cleaning

- When necessary, cleaning should occur only with isopropyl alcohol at room temperature for a duration of no more than one minute. Dry at room temperature before use.

Do not clean the LEDs by the ultrasonic. When it is absolutely necessary, the influence of ultrasonic cleaning on the LEDs depends on factors such as ultrasonic power and the

- cause damage to the LED.

5. Heat Management

- Heat management of LEDs must be taken into consideration during the design stage of LED application. The current should be de-rated appropriately by referring to the de-rating curve found in each product specification.

- The temperature surrounding the LED in the application should be controlled. Please refer to the data sheet de-rating curve.
6. ESD (Electrostatic Discharge)
- Electrostatic discharge (ESD) or surge current (EOS) can damage LEDs.
 - An ESD wrist strap, ESD shoe strap or antistatic gloves must be worn whenever handling LEDs.
 - All devices, equipment and machinery must be properly grounded.
 - Use ion blower to neutralize the static charge which might have built up on surface of the LEDs plastic lens as a result of friction between LEDs during storage and handing.
7. Other
- Above specification may be changed without notice. EVERLIGHT will reserve authority on material change for above specification.
 - When using this product, please observe the absolute maximum ratings and the instructions for using outlined in these specification sheets. EVERLIGHT assumes no responsibility for any damage resulting from use of the product which does not comply with the absolute maximum ratings and the instructions included in these specification sheets.
 - These specification sheets include materials protected under copyright of EVERLIGHT corporation. Please don't reproduce or cause anyone to reproduce them without EVERLIGHT's consent.

EVERLIGHT ELECTRONICS CO., LTD.
Office: No 25, Lane 76, Sec 3, Chung Yang Rd,
Tucheng, Taipei 236, Taiwan, R.O.C

Tel: 886-2-2267-2000, 2267-9936
Fax: 886-2267-6244, 2267-6189, 2267-6306
<http://www.everlight.com>